

Sigma vermogentesters:

The Sigma dynamometer is a aircooled dyno special made for testing long time and lots of power, you can use it in workshop or "on road".

The power tester works according to the generator principle. The PTO is linked to the gearbox that doubles the speed.

It drives the generator and by means of software or the handheld control can be responsible for the generator. The energy is directly by air-cooled resistors converted into heat and leave the power so tester.



The system is both mobile to obtain as static and in two types i.e. the Sigma 50 and the Sigma 60. The housing can be at a little additional price in your own company colors can be painted.

The machine is manufactured with good equipment and has therefore an industrial look. The frame is made of galvanised steel 3 and 6 mm.

Unique to the Sigma types is that this long time to cope with a high torque, something the retarder brakes cannot, this store the heat in the retarder which makes a very short test time arises at higher torque.

The Sigma 60 tester can be a high torque of 4556 Nm, depending on the engine speed (600 rpm) and a power of 700 hp (900 rpm).

There are ample storage for the PTO shafts and there is a safe platform for the laptop at the front of the machine.

The control and readout of the Sigma machine in two ways.

In the standard version is the tester is controlled via the handheld controller.

There may also be selected for the operating with the Sigma software with print function.





Technical specifications:

The Sigma testers have a 230 volt power supply max. 13 Amp. This is for the control and for the cooling fan, a 10 meter cable is standard supplied. The cooling is done by air.

	Sigma 50	Sigma 60
PTO (270-1250 rpm)	515 Pk/380KW @1000 rpm	680 Pk/500KW @1000 rpm
Direct (480-2200 rpm)	515 Pk/380KW @1800 rpm	680 Pk/500KW @1800 rpm
Torque @ 800 rpm	3170 Nm	4150 Nm
Torque @ 1400 rpm	1790 Nm	2340 Nm
Weight Mobile	1600 Kg	1800 Kg
HxBxL Mobile	1680x1745x3775 MM	
Weight Static	1400 Kg	1600 Kg
HxBxL static	1590x1380x2445 MM	

Your benefits:

- automatic test program (also walk-in/warm-up)
- possibility to diagnose and fix in the Workshop
- accurate system (guaranteed accuracy of 98%)
- possibility to produce a test report and power and torque charts
- ideal for duration test
- easy to operate
- customer can multiple tractors testing(at mobile version)
- Storage facility of 4 pieces pto

Our service and aftercare:

for you to make optimum use of your power tester, offers PPC when you purchase a power tester a product training in Holland.

It is also your power tester after purchase followed by an after sales representative.

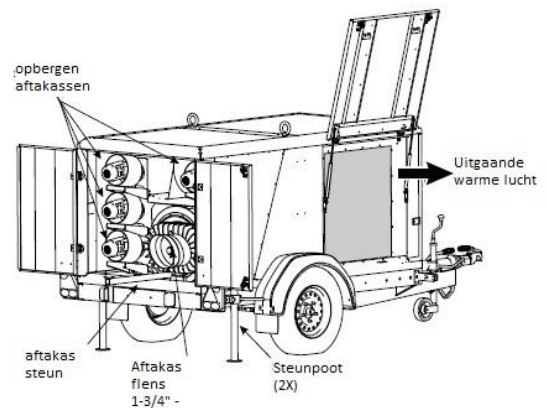

Sigma 50	Sigma 60	@ 20 graden Celsius	@ 40 graden Celsius
400Pk (300Kw)	570Pk (420Kw)	50 min.	25 min.
340Pk (260Kw)	500Pk (370Kw)	3 uur	1.5 uur
From 20 - 270Pk (200Kw)	From 20 - 410Pk (300Kw)	continu	continu

The above data are calculated and can differ per assembly.

At the maximum testing is a cooling break of 30 min. sufficient for a next test.

For testing of a separate engine gearbox is a special necessary.